

Product Information Sheet

COMMISSION DELEGATED REGULATION (EU) 2019/2015 with regard to energy labelling of light sources

Supplier's name or trade mark: Source

Supplier's address: SGD, Unit 7/8 Ashbourne Business Centre Ballybin Road Ashbourne Co. Meath Ireland A84YP58

Model identifier: SCIRSEN BL WH CCT

Type of light source:

Lighting technology used:	LED	Non-directional or directional:	DLS
Light source cap-type (or other electric interface)	NO CAP TYPE		
Mains or non-mains:	MLS	Connected light source (CLS):	No
Colour-tuneable light source:	No	Envelope:	-
High luminance light source:	No		
Anti-glare shield:	No	Dimmable:	Yes

Product parameters

Parameter	Value	Parameter	Value
-----------	-------	-----------	-------

General product parameters:

Energy consumption in on-mode (kWh/1000 h), rounded up to the nearest integer	18	Energy efficiency class	E
Useful luminous flux (ϕ_{use}), indicating if it refers to the flux in a sphere (360°), in a wide cone (120°) or in a narrow cone (90°)	2 000 in Sphere (360°)	Correlated colour temperature, rounded to the nearest 100 K, or the range of correlated colour temperatures, rounded to the nearest 100 K, that can be set	3 000 or 4 000 or 6 500
On-mode power (P_{on}), expressed in W	18,0	Standby power (P_{sb}), expressed in W and rounded to the second decimal	-
Networked standby power (P_{net}) for CLS, expressed in W and rounded to the second decimal	-	Colour rendering index, rounded to the nearest integer, or the range of CRI-values that can be set	84
Outer dimensions without separate control gear, light-	Height	221	Spectral power distribution in the range 250 nm to 800 nm, at full-load
	Width	221	
	Depth	85	
			See image in last page

ing control parts and non-lighting control parts, if any (millimetre)			
Claim of equivalent power ^(a)	-	If yes, equivalent power (W)	-
		Chromaticity coordinates (x and y)	0,435 0,403
Parameters for directional light sources:			
Peak luminous intensity (cd)	560	Beam angle in degrees, or the range of beam angles that can be set	119
Parameters for LED and OLED light sources:			
R9 colour rendering index value	16	Survival factor	1,00
the lumen maintenance factor	0,96		
Parameters for LED and OLED mains light sources:			
displacement factor (cos ϕ_1)	0,00	Colour consistency in McAdam ellipses	3
Claims that an LED light source replaces a fluorescent light source without integrated ballast of a particular wattage.	.. ^(b)	If yes then replacement claim (W)	-
Flicker metric (Pst LM)	0,0	Stroboscopic effect metric (SVM)	0,0

(a)'.': not applicable;

(b)'.': not applicable;

Installation and Operating Manual

Product Codes: SCIRLED BL/WH - CCT, SCIR SEN BL/WH - CCT



Features	SCIRLED BL/WH-CCT SCIR SEN BL/WH-CCT
Shape	Circular
Multi Wattage	9w, 12w, 18w
Input Voltage	220-240V AC
Lumen Output	1100Lm, 1500Lm, 2000Lm
Lumen/Watt	110LM/W
CCT	3000k, 4000k, 6500k
Lifespan	50000hrs
Beam Angle	115°
Dimensions	Ø 211mm x D 55mm

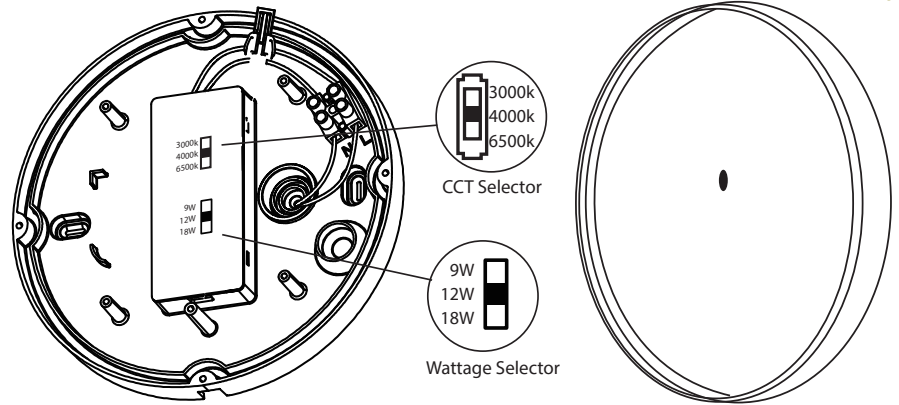

General Safety Instructions

Please read the operating instructions for the LED luminaire before use. The operating instructions are part of the product. They contain installation, maintenance and recycling information about the product. They must be enclosed when passing the device to third parties.

Safety Precautions and Warranty

- This product must be installed by a qualified electrician.
- Please read the manual before attempting to install the fitting.
- Do not open the fitting without reading the instructions.
- If mounting outdoors, use a suitable outdoor cable
- The LED luminaire cannot be repaired and must be disposed of if faulty.
- Ensure sufficient ventilation of the product.
- Do not cover during operation.
- Do not install within reach of children or animals.
- This product is not suitable for dimming
- SGD is not liable for damage caused by non adherence to the instructions.

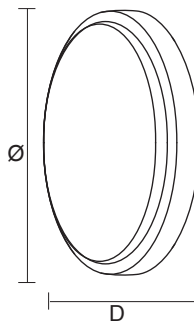

Required for mounting	
	1x
	4x
	2x
	2x

Installation Instructions

1. Ensure that the main power source is switched off
2. Drill two holes at the desired height of the fitting. Use the two designated points from the fixture as spacing between the holes.
3. Connect the luminaire to the mains supply with the terminal block inside the luminaire.
4. Turn the swivel to secure the cable
5. Fix the luminaire to the suitable position. Use the round rubber rings around the screws from the inside of the luminaire to make it waterproof
6. Activate the power source

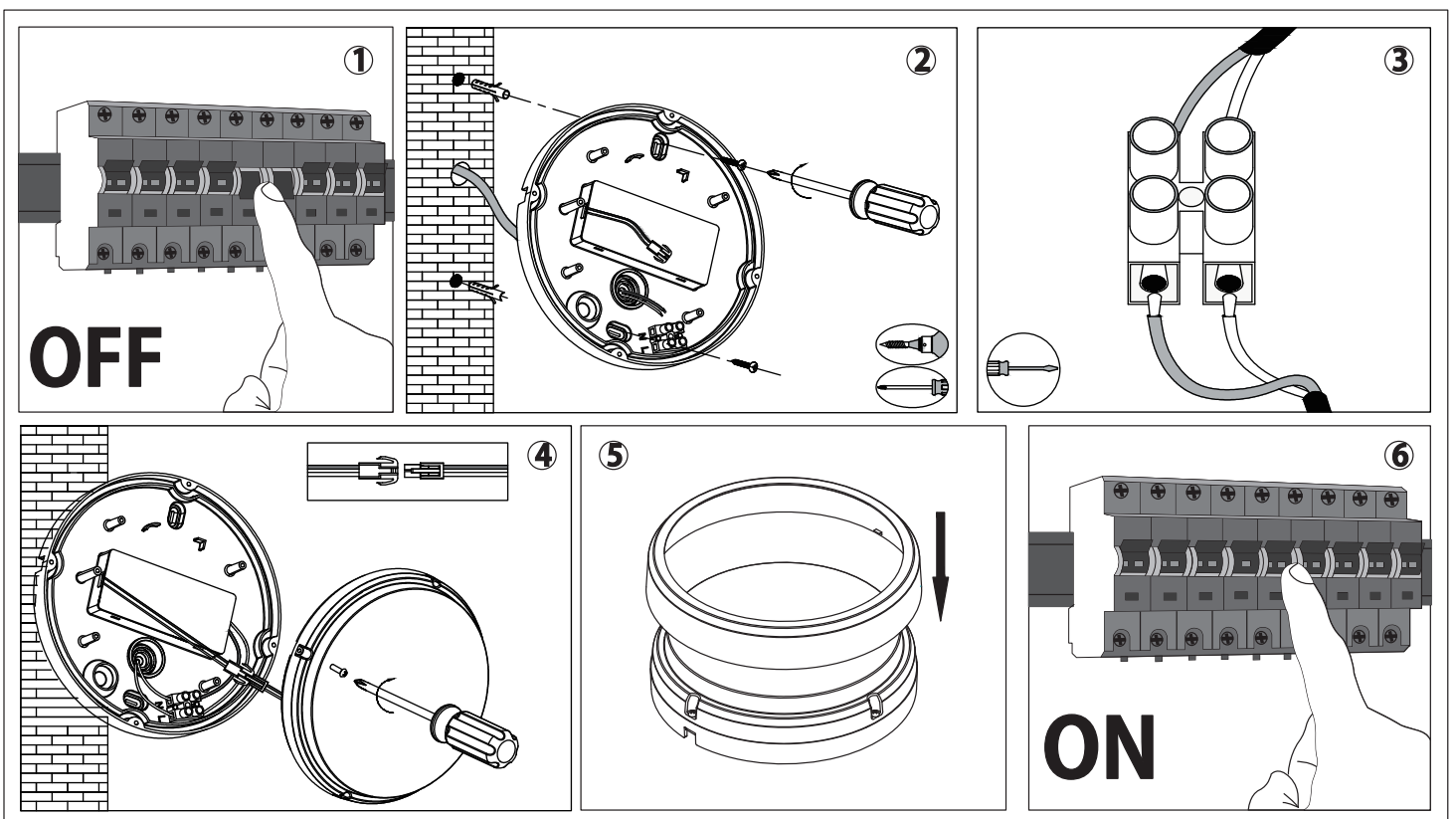

PIR SENSOR

Code: SCIR SEN BL/WH - CCT

Features	SCIRSEN BL/WH-CCT
Detection Range	Max 4M
Detection Angle	120°
Time Adjustment	Hold time 5s/90s/5mins/10mins Stand-by period 0s/10s/15min/+∞
Ambient Light	Disabled or 25Lux
Max mounting height	3M

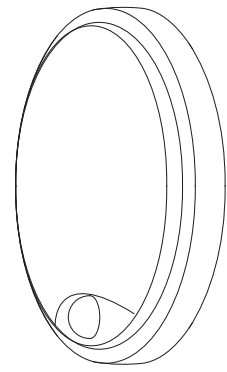

Settings

Stand-by dimming level 20%

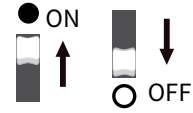

Sensitivity	
DIP switch	1
100%	●
50%	○

In this area, movement will be detected and able to trigger the sensor. 100% detection area is also known as strong sensitivity.

Hold-time		
DIP switch	2	3
5s	●	●
90s	○	●
5min	●	○
10min	○	○

The period of light keeping 100% brightness after moving objects leave the detection area.

Daylight threshold		
DIP switch	4	
Disable	●	
25Lux	○	

Definition of the ambient brightness when the ambient brightness is lower than the preset specific lux amount. The sensor will work when its preset is disabled, the sensor works everytime it detects motion regardless the ambient brightness.

Stand-by period		
DIP switch	5	6
0s	●	●
10s	○	●
15min	●	○
+∞	○	○

The period of light remaining at low output before being switched off. When preset as +∞ the light will always remain at low output if no movement happens in the detection area.

Factory Settings:

1 - on, 2 - off, 3 - on, 4 - on, 5 - on, 6 - on



Product end of life instruction.

This Lighting product is in the scope of EU 2019/2020 directive on Waste Electrical and Electronic Equipment (WEEE). This product must be disposed according to the legislation. This document is intended for use by end of life recyclers or treatment facilities. It provides the basic information to assure an appropriate end of life treatment for the components and materials of the product. Please follow pictured diagram showing how to dismantle the product into different components which should be disposed of correctly. These components consist of plastic, metal and electronic materials. It is the responsibility of the end user to dispose of this product correctly. Contact www.weeeireland.ie or your local council for further information.

SCIR SEN / SCIRLED DISASSEMBLY DIAGRAM

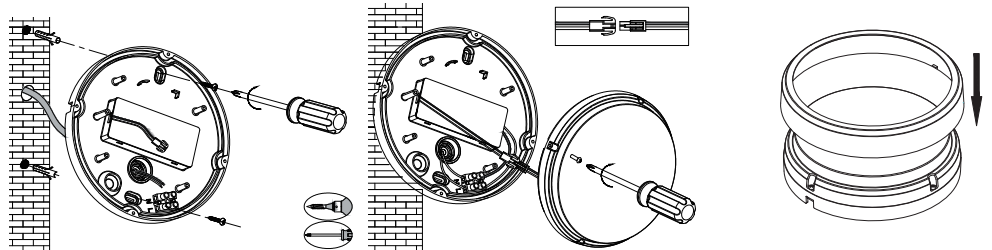

Care and Warranty

Before cleaning the unit, disconnect from other components. Do not use aggressive cleaning agents. The unit has been carefully checked for defects, nevertheless if you do have cause for complaint, please return it to the retailer together with proof of purchase. We offer a 3 year warranty from date of purchase. We are not liable for damage arising from incorrect handling, improper use or wear and tear. SGD reserves the right to make technical modifications.

CE declaration: LVD 2014/35/EU, EMC 2014/30/EU, RoHS 2011/65/EU

Non-Replaceable Light Source

For more information contact:



Solas Geal Distribution

Unit 7/8 Ashbourne Business Centre, Ballybin Road, Ashbourne, Co. Meath, Ireland, A84 YP58
Phone: 00353 1 835 7447 Website: www.sgd.ie



Spectrum Test Report

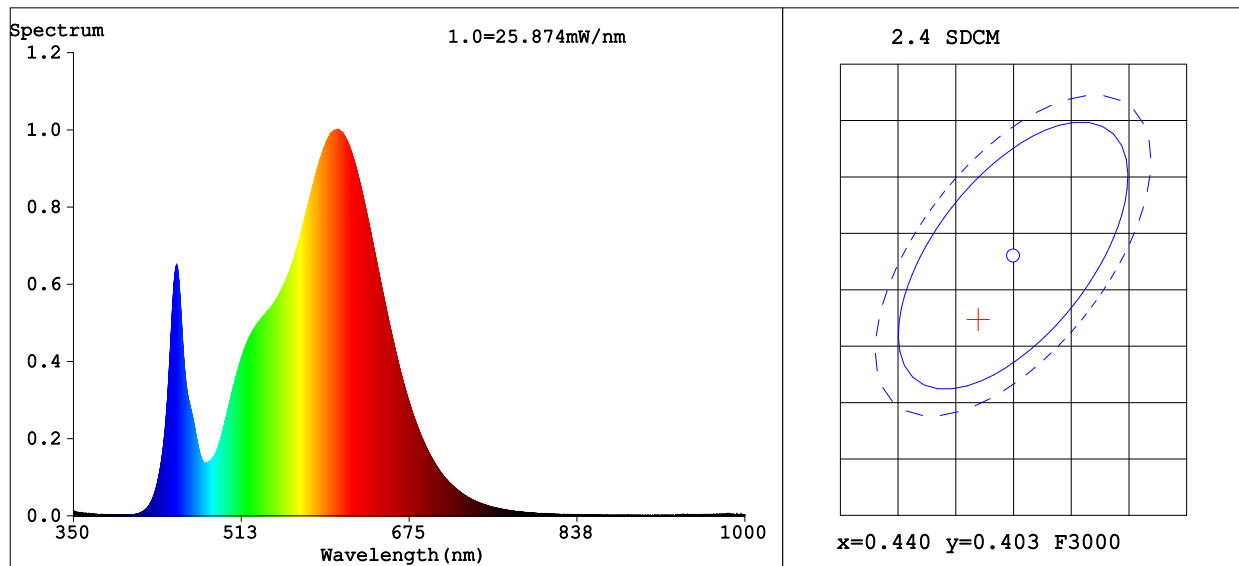

Color Parameters:

Chromaticity Coordinate: x=0.4370 y=0.3973/u'=0.2535 v'=0.5187

CCT=2944K (Duv=-0.0027) Dominant WL:Ld =584.1nm Purity=50.4%

Ratio: R=23.6% G=74.1% B=2.3% Peak WL:Lp=607.1nm FWHM=126.9nm

Render Index: Ra=83.1

R1 =82 R2 =91 R3 =96 R4 =82 R5 =82 R6 =89 R7 =82

R8 =59 R9 =9 R10=79 R11=82 R12=72 R13=84 R14=99 R15=75

Photo Parameters:

Flux = 1228 lm Eff. : 139.56 lm/W Fe = 3.751 W

Electrical parameters:

V = 230.00 V I = 0.07000 A P = 8.800 W PF = 0.5450

LEVEL:OUT WHITE:ANSI_3000K

Status: Integral T = 25 ms Ip = 50317 (77%)

Model: SCIRSEN BL/WH CCT
Tester: SGD LTD
Temperature: 25Deg
Manufacturer: SGD LTD

Number: 1
Date: 2024-09-29 13:22
Humidity: 65.0%
Remarks: IRL5743/1# 9W

Spectrum Test Report

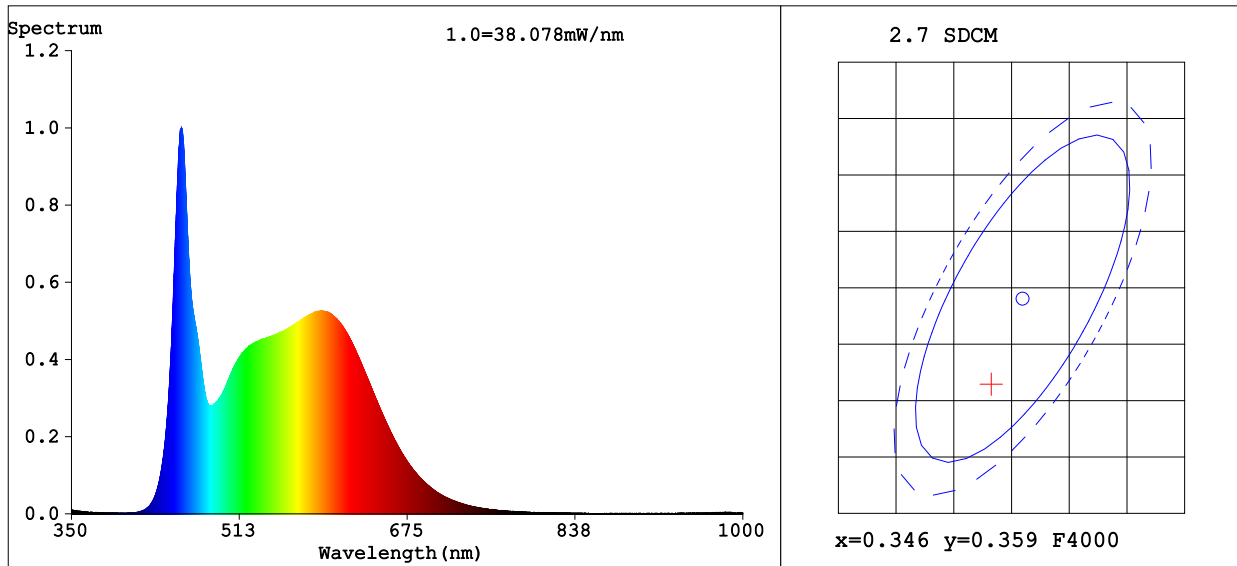

Color Parameters:

Chromaticity Coordinate: $x=0.3433$ $y=0.3514$ / $u'=0.2103$ $v'=0.4843$
 CCT=4270K (Duv=0.0006) Dominant WL:Ld =571.0nm Purity=8.4%
 Ratio:R=16.5% G=77.9% B=5.6% Peak WL:Lp=456.5nm FWHM=21.7nm
 Render Index:Ra=87.5
 R1 =88 R2 =96 R3 =95 R4 =84 R5 =87 R6 =91 R7 =86
 R8 =72 R9 =29 R10=89 R11=85 R12=65 R13=92 R14=98 R15=84

Photo Parameters:

Flux = 1268 lm Eff. : 151.00 lm/W Fe = 4.064 W

Electrical parameters:

V = 230.00 V I = 0.06700 A P = 8.400 W PF = 0.5380

LEVEL:OUT WHITE:ANSI_4000K

Status: Integral T = 22 ms Ip = 50045 (76%)

Model:SCIRSEN BL/WH CCT
 Tester:SGD LTD
 Temperature:25Deg
 Manufacturer:SGD LTD

Number:2
 Date:2024-09-29 13:31
 Humidity:65.0%
 Remarks:IRL5743/1# 9W

Spectrum Test Report

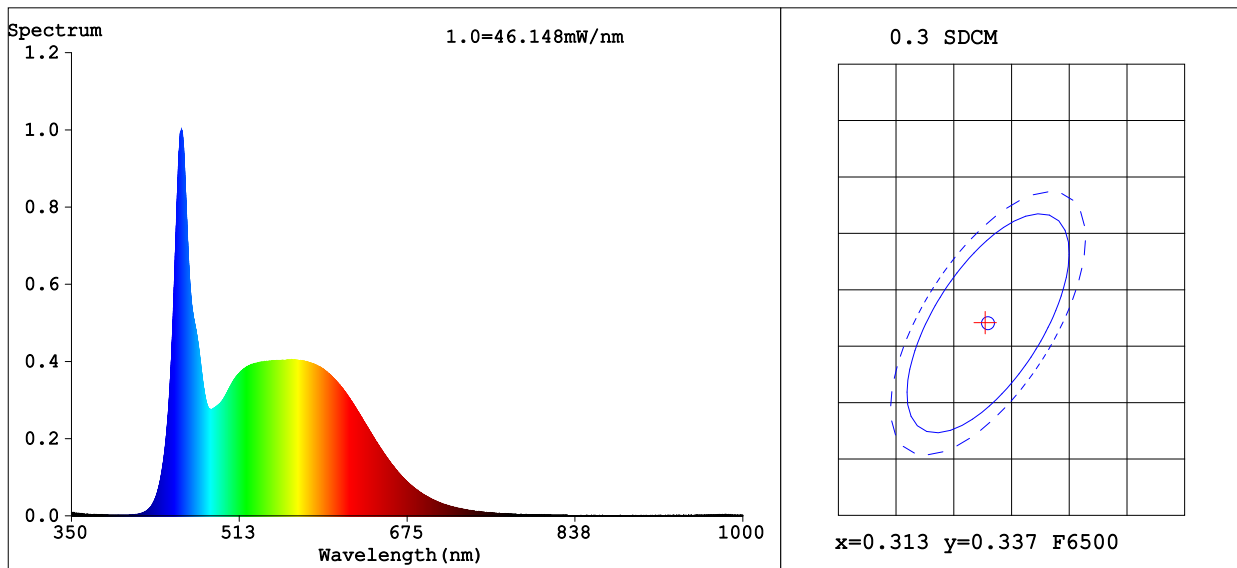

Color Parameters:

Chromaticity Coordinate: $x=0.3127$ $y=0.3370$ / $u'=0.1949$ $v'=0.4726$
 CCT=6446K (Duv=0.0072) Dominant WL:Ld =494.0nm Purity=6.7%
 Ratio:R=13.7% G=79.6% B=6.7% Peak WL:Lp=456.5nm FWHM=21.1nm
 Render Index:Ra=85.1
 R1 =84 R2 =95 R3 =94 R4 =79 R5 =83 R6 =90 R7 =85
 R8 =70 R9 =18 R10=86 R11=80 R12=57 R13=88 R14=97 R15=79

Photo Parameters:

Flux = 1254 lm Eff. : 149.25 lm/W Fe = 4.075 W

Electrical parameters:

V = 230.00 V I = 0.06800 A P = 8.400 W PF = 0.5390
 LEVEL:OUT WHITE:ANSI_6500K

Status: Integral T = 17 ms Ip = 46867 (72%)

Model:SCIRSEN BL/WH CCT
 Tester:SGD LTD
 Temperature:25Deg
 Manufacturer:SGD LTD

Number:3
 Date:2024-09-29 13:33
 Humidity:65.0%
 Remarks:IRL5743/1# 9W

Spectrum Test Report

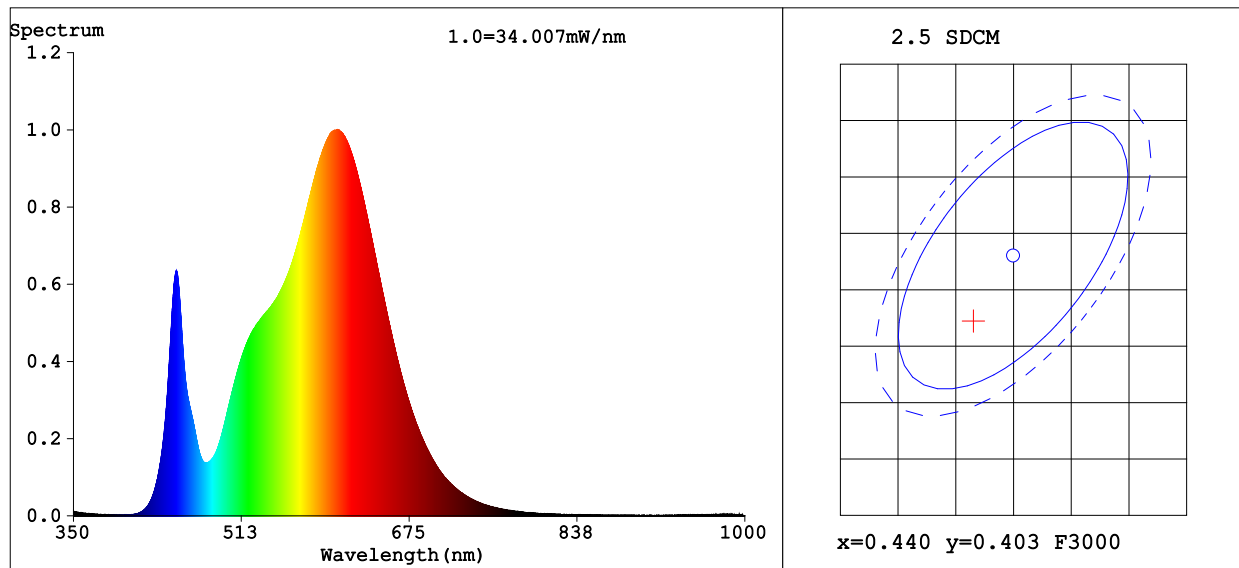

Color Parameters:

Chromaticity Coordinate: x=0.4366 y=0.3972/u'=0.2533 v'=0.5186
 CCT=2950K(Duv=-0.0027) Dominant WL:Ld =584.0nm Purity=50.2%
 Ratio:R=23.5% G=74.2% B=2.3% Peak WL:Lp=605.5nm FWHM=127.1nm
 Render Index:Ra=82.9
 R1 =82 R2 =91 R3 =96 R4 =82 R5 =82 R6 =89 R7 =82
 R8 =59 R9 =8 R10=79 R11=82 R12=72 R13=84 R14=98 R15=75

Photo Parameters:

Flux = 1618 lm Eff. : 135.93 lm/W Fe = 4.939 W

Electrical parameters:

V = 230.00 V I = 0.09100 A P = 11.90 W PF = 0.5690
 LEVEL:OUT WHITE:ANSI_3000K

Status: Integral T = 17 ms Ip = 44974 (69%)

Model:SCIRSEN BL/WH CCT
 Tester:SGD LTD
 Temperature:25Deg
 Manufacturer:SGD LTD

Number:4
 Date:2024-09-29 13:35
 Humidity:65.0%
 Remarks:IRL5743/1# 12W

Spectrum Test Report

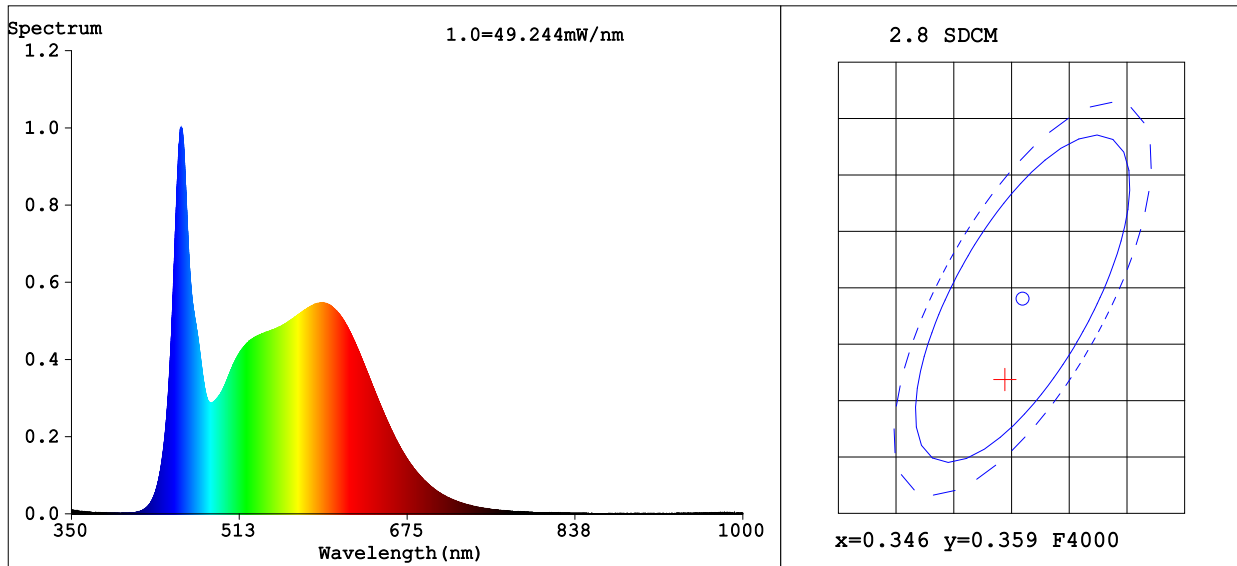

Color Parameters:

Chromaticity Coordinate: x=0.3445 y=0.3518/u'=0.2109 v'=0.4847
 CCT=4226K(Duv=0.0004) Dominant WL:Ld =572.0nm Purity=8.9%
 Ratio:R=16.6% G=77.9% B=5.5% Peak WL:Lp=456.5nm FWHM=22.6nm
 Render Index:Ra=87.5
 R1 =88 R2 =96 R3 =95 R4 =85 R5 =87 R6 =91 R7 =86
 R8 =71 R9 =29 R10=89 R11=85 R12=66 R13=91 R14=98 R15=83

Photo Parameters:

Flux = 1698 lm Eff. : 142.68 lm/W Fe = 5.439 W

Electrical parameters:

V = 230.00 V I = 0.08700 A P = 11.90 W PF = 0.5640
 LEVEL:OUT WHITE:ANSI_4000K

Status: Integral T = 17 ms Ip = 50032 (76%)

Model:SCIRSEN BL/WH CCT
 Tester:SGD LTD
 Temperature:25Deg
 Manufacturer:SGD LTD

Number:5
 Date:2024-09-29 13:39
 Humidity:65.0%
 Remarks:IRL5743/1# 12W



EU DECLARATION OF CONFORMITY

Manufacturers Name: Solas Geal Distribution
Unit 7/8 Ashbourne Business Centre, Ballybin Road, Ashbourne, Co. Meath, A84 YP58.

Declaration Number:
003-SCIRLED BL/WH-CCT . 003-SCIRSEN BL/WH-CCT
003-SOVLED BL/WH-CCT . 003-SOVSEN BL/WH-CCT

This declaration of conformity is issued under the sole responsibility of the manufacturer.

Products:
Oval & Circular Moisture proof LED IP65 Wall and Ceiling lights Multi Watt CCT

Model Number:
SCIRLED BL/WH-CCT, SCIRSEN BL/WH-CCT,
SOVLED BL/WH-CCT, SOVSEN BL/WH-CCT

The product/model of the declaration described above is in conformity with the relevant Community harmonisation legislation.

Low Voltage Directive (2014/35/EU)
Directive 2009/125/EC
(EU) 2019/2015 Regulation on Energy Labelling for Light Sources.
(EU) 2019/2020 Ecodesign Requirements for Light Sources and Separate Control Gears

The product/model of the declaration described above is in conformity with the standards and technical specifications listed below:

EEN IEC 55015:2019+A11:2020, EN IEC 61547:2023, EN IEC 61000-3-2:2019/A1:2021
EN 61000-3-3:2013/A2:2021/AC:2022-01



Signed:

Date: 16/10/24

Place of Issue: Republic of Ireland

