



# Surface/Recessed Self Testing IP65 5w Emergency Downlight

Code	Description
SEM-SWDL	Recessed/Surface Self Testing 5w IP65 Emergency Downlight

## Features

Emergency Self Test Surface & Recessed Downlight  
 Two click on lenses supplied for different Light Distributions:  
 Open Lens: Beam Angle: 144°, 500Lm +/-10%  
 Corridor Lens: Beam Angle: 128°, 425Lm +/-10%  
 Power: 5w  
 IP Rating: IP65  
 Cutout: 50mm  
 Colour Temp: 5700k+/-355k  
 Surface Mounting Accessory included  
 5 Yr Guarantee  
 Voltage: 220-240V, 50/60Hz  
 Non-maintained / Self Testing  
 Compliant with BS EN 62034  
 BS EN 60598-2-22:2014 + A1:2020

**Battery**  
 4.0Ah 3.2V  
 LiFeP04 (Lithium Iron Phosphate) Battery  
 3 Hours Duration  
 3 years warranty

**Indoor Use**  
 Exits  
 Corridors  
 Escape Routes

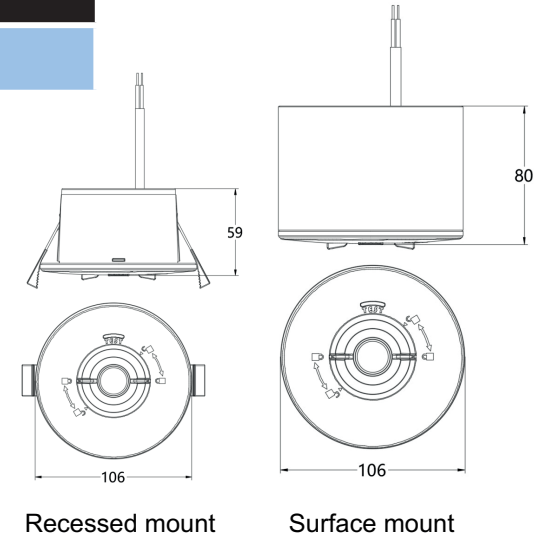

Download Specification

